



UNIVERSITY OF CAMBRIDGE INTERNATIONAL EXAMINATIONS
General Certificate of Education Advanced Level

BUSINESS STUDIES

9707/33

Paper 3

October/November 2012

CASE STUDY

3 hours

Additional Materials: Answer Booklet/Paper

READ THESE INSTRUCTIONS FIRST

If you have been given an Answer Booklet, follow the instructions on the front cover of the Booklet.

Write your Centre number, candidate number and name on all the work you hand in.

Write in dark blue or black pen.

You may use a soft pencil for any diagrams, graphs or rough working.

Do not use staples, paper clips, highlighters, glue or correction fluid.

Section A

Answer **all** questions.

Section B

Answer **one** question.

You are advised to spend 40 minutes on Section B.

The businesses described in this question paper are entirely fictitious.

At the end of the examination, fasten all your work securely together.

The number of marks is given in brackets [] at the end of each question or part question.



This document consists of **7** printed pages and **1** blank page.



Leo's Fantastic Flowers (LFF)

Leo had the idea for this business when he could not find any flowers to buy for a friend's wedding. There were no local flower shops. He went to a nearby town to find one and was told by the owner of the only flower shop that it is difficult to obtain supplies of fresh flowers throughout the year. After his friend's wedding he started thinking seriously about setting up his own flower business. 5

As Leo had just sold his machinery leasing company, his potential new business venture actually had two of the requirements for success:

- capital – from the sale of his previous business
- a market gap – discovered from his own attempts to buy flowers.

Leo is self-confident and hard working. It only took him one day to do some secondary market research, contact some overseas flower growers and think of a business name: Leo's Fantastic Flowers (LFF). In his first year he opened three flower shops but his plan was always to go into flower growing too. 10

Pressure group activity

Supplies of flowers from foreign growers are unreliable. Flowers from countries with good climate conditions are flown in from up to 5000 kilometres away. Environmental pressure groups in Leo's country campaigned to encourage consumers to 'buy local'. They wanted consumers to stop buying goods which were produced overseas and then transported into the country at great expense and damage to the environment because of emissions from ships and aircraft. 15
20

Leo's reaction to this campaign had been to build a large glasshouse, heated by an oil boiler, to grow locally some of the flowers sold in LFF shops. He claimed in his advertisements that 'local flowers are greener!' Actually Leo estimated that the emissions from the boiler heating the glasshouse, had the same environmental effect as caused by having flowers flown in. 25

Solar heated glasshouses – a really green solution

At a flower industry trade fair, Leo saw some promotional material from a company called GreenGlass for glasshouses heated and cooled by solar (sun) energy panels. These glasshouses can be leased for five years. They are fitted with large solar panels to provide energy for heating the glasshouses in cold periods and for cooling in hot periods when flowers could die. He asked for a quotation to supply a glasshouse with these solar panels. The supplying company did more than provide a quotation. After visiting LFF and finding out which plants were grown and in which quantities, it supplied Leo with the estimates in Table 1. 30

Table 1: Estimates for glasshouse heated by solar panels

35

Annual fixed costs including leasing costs	Contribution per bunch of flowers	Annual capacity (bunches of flowers)	Net Present Value over 5 years at 5% discount rate
\$129 000	\$3	100 000	\$335 000

This data allowed Leo to compare the break-even output and potential profitability of this new glasshouse with the existing one – see Appendix A. However, replacing the existing glasshouse with the new building would disrupt flower growing during a busy flower-buying season. Leo also wondered if foreign flowers were likely to become cheaper as other countries expand their flower industry. 40

Critical path analysis for building the new glasshouse

If the new glasshouse is approved by the Board of Directors, Leo has decided that GreenGlass would only supply the basic structure and the solar energy panels. He would subcontract the work for removing the existing glasshouse and constructing the new one to a small local building firm. He said to the owner of this firm, Bill: ‘We must have this glasshouse open as soon as possible or we may lose sales to our competitors. Do you think it could be ready within three months of closing the old glasshouse?’ 45

Leo and Bill worked out a simple critical path network diagram. See Appendix B. ‘If we use this as our plan for the project, it looks certain that it should be ready within 3 months of starting it’ Leo said. 50

Improving employee performance

Ten years after being set up, LFF now has 36 flower shops. Each shop has one full-time manager. These managers are given responsibility for recruiting the workers needed in their LFF shop. Each manager has an annual budget to cover recruitment costs, training costs and wages. If there is a favourable variance on this budget at the end of the year then a proportion of this is added to the manager’s bonus. Most shop workers are employed on part-time contracts. Many are employed for six months at a time so their contracts can be ended if their performance is unsatisfactory or if flower demand falls for seasonal reasons. The latest data on employee performance worries Leo. It shows that, over 12 months, labour turnover is up by 15%, absenteeism up by 18% and customer complaints about incorrect flower orders have increased by 20%. He argued with the Human Resources Director over how to improve employee performance. ‘LFF’s profits are being reduced by these problems. We need to look at how we recruit, train and pay our shop workers. Why not put them on a profit-sharing scheme – or just commission on sales – and try to gain their loyalty?’ suggested Leo when he met the Human Resources Director. She replied: ‘We could spend money on trying to solve these problems but I believe that, with rising unemployment amongst low-skilled workers, these problems will solve themselves.’ 55
60
65
70

Marketing flowers – would selling through the Internet be effective?

The growth of e-commerce has started to impact on the sale of flowers. For example, ‘e-Flowers’ is a highly successful flower business that only sells through the Internet. The success of this and similar companies encouraged Leo to report to the Board of Directors: 75

‘LFF cannot ignore the impact of e-commerce. It gives us an opportunity to reach a much bigger market. However, there is a threat of global competition from rivals offering low prices, discounted delivery, huge product ranges and big promotional campaigns. If we can change our existing marketing strategy successfully towards Internet users (or perhaps just certain market segments) then we may be able to close some shops and make a higher contribution on each bunch of flowers sold.’ 80

Planning for the future

Leo is planning the future strategies the business could pursue over the next five years. He wants to produce a detailed corporate plan for this period. This will explain LFF's objectives and how they could be achieved. He has asked each functional director to help in this process. He is opposed by some directors as it is the first time the company has planned in a formal way. 'I really do have better things to do with my time than speculate about what we might be doing in four or five years time. We have no idea of the future state of the economy, potential competition or possible changes in consumer tastes. I am much more concerned about next week's cash flow position' said the Finance Director. The Human Resources Director agreed and said: 'We need to solve the labour performance problems before we spend time and money planning for the future.' However, Leo insisted on the directors thinking 'for the long term'. 'It is because the future is so uncertain that we need to make plans for more than one year ahead' he insisted. 'Possible future strategies – such as opening shops abroad, building more glasshouses, taking over competitors or developing e-commerce – will all need detailed planning.'

Appendix A: Break-even chart for the existing glasshouse

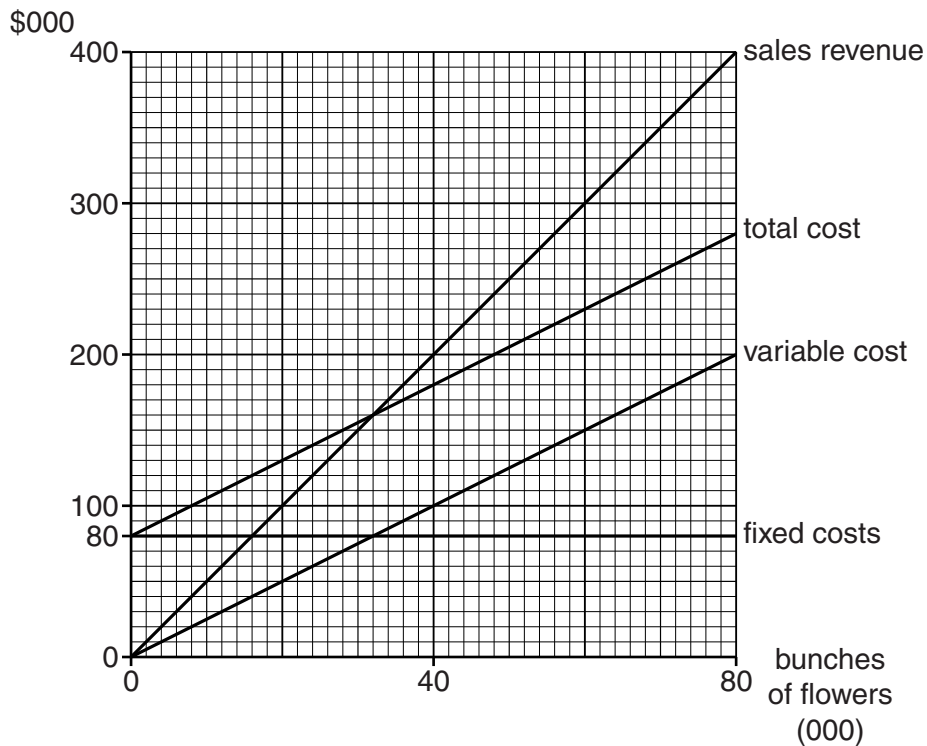

Appendix B: Critical path network for constructing the glasshouse heated by solar panels
 (Durations for each activity are in days and are shown below each activity.)

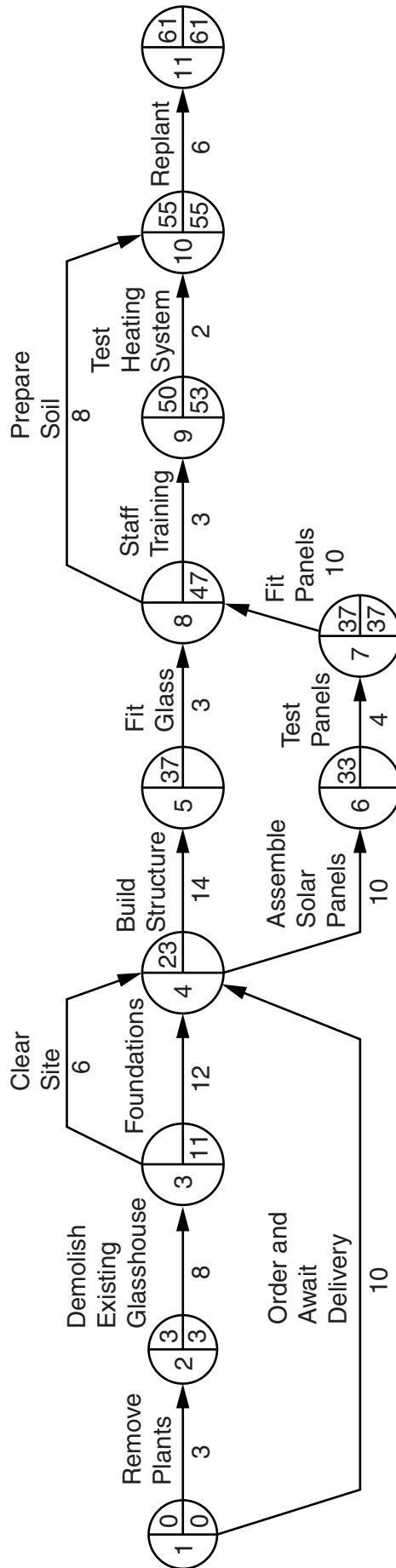

Appendix C: Forecast data to be used by Leo in developing LFF's corporate plan

Data for country LFF operates in	2013	2014	2015
Annual GDP growth %	5	4	2
Exchange rate index against other currencies (2012 = 100)	105	90	85
Interest rates %	2	4	5
Number of new flower retailers expected to open	12	16	25
% of total flower sales made through Internet	10	12	17

Section A

Answer **all** questions in this section.

- 1 Analyse Leo's role in the success of LFF in its first year. [10]
- 2 (a) Refer to Table 1. Calculate for the glasshouse heated by solar panels:
- (i) annual break-even level of output [3]
 - (ii) annual net profit at maximum capacity. [3]
- (b) Recommend whether LFF should invest in this project. Justify your recommendation using your results from (a), the break-even graph in Appendix A and other information. [16]
- 3 Discuss how LFF might solve the human resource problems in its shops in order to increase long term profitability. [14]
- 4 (a) Refer to Appendix B. State the earliest start time at:
- (i) node 3 [1]
 - (ii) node 8. [1]
- (b) Refer to Appendix B. State the latest finish time at:
- (i) node 4 [1]
 - (ii) node 5 [1]
 - (iii) node 6. [1]
- (c) State the minimum duration of the project. [1]
- (d) Discuss the usefulness of this critical path analysis in managing the project to construct a glasshouse heated by solar panels. [12]
- 5 Discuss the most important features of a marketing plan that LFF could develop to sell flowers successfully through the Internet (e-commerce). [16]

Section B

Answer **one** question only.

- 6 Evaluate the extent to which analysis of the data in Appendix C will be sufficient to enable LFF's management to develop future strategies. [20]
- 7 Discuss the arguments for and against Leo's decision to invest time and resources in long term corporate planning. [20]

BLANK PAGE

Permission to reproduce items where third-party owned material protected by copyright is included has been sought and cleared where possible. Every reasonable effort has been made by the publisher (UCLES) to trace copyright holders, but if any items requiring clearance have unwittingly been included, the publisher will be pleased to make amends at the earliest possible opportunity.

University of Cambridge International Examinations is part of the Cambridge Assessment Group. Cambridge Assessment is the brand name of University of Cambridge Local Examinations Syndicate (UCLES), which is itself a department of the University of Cambridge.